

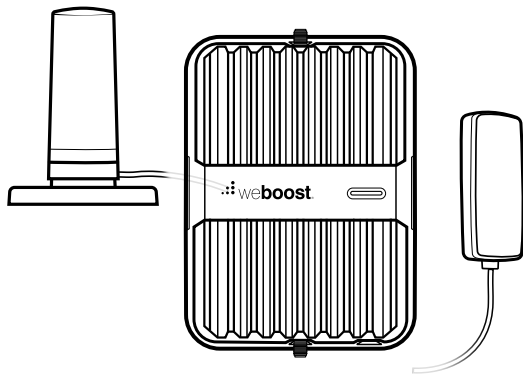



Installation Guide



Drive Reach Flex Fleet

Professional Vehicle Cell Signal
Booster Kit

Use our  **weBoost App** to guide you through the installation. See inside page for more details.



Download the weBoost App

Use our app to guide you through setting up a weBoost cell phone signal booster in your home, business, or vehicle. Boost every network, including 5G, right away.



Index

Package Contents	1
STEP 1 Mount the Outside Antenna	2
STEP 2 Mount the Inside Antenna	5
STEP 3 Hardwiring to Power	6
STEP 4 Connect Coax Cables to Booster	8
STEP 5 Connect Power Supply to Booster	9
Booster Light Patterns	10
Troubleshooting	12
Safety Guidelines	14
Antenna Info	16
Specifications	17
Warranty	18

Package Contents



Booster &
Mounting
Bracket

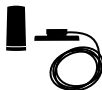

Outside NMO Antenna
+ Magnet NMO Mount
with 14 ft. Cable



In-Vehicle
Antenna



Power Supply,
Hardwire Power
Supply & In-line
Fuse Holder



Mounting Plate
for Aluminum
Vehicle



O-Ring Lubricant
Packet

STEP 1 Mount the Outside Antenna

Identify a location for NMO outside antenna on the top of your vehicle that is:

- Near the center of the roof
- At least 12 inches away from any other antennas
- At least 6 inches away from any windows

Do a soft install before finalizing the antenna mounting point. Setup the system by routing the cable through an open door or window. Complete the setup instructions, verifying the system works as desired before finishing the remaining portion of this step.

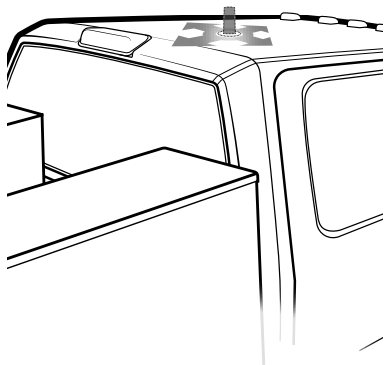

(STEP 1 cont.)

Once the antenna location point has been identified, route the cable into the vehicle. The cable is strong enough that it may be shut in most vehicle doors without damage or the cable can be routed into the vehicle through the third brake light, as shown.

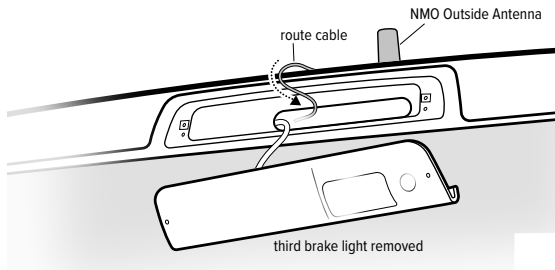
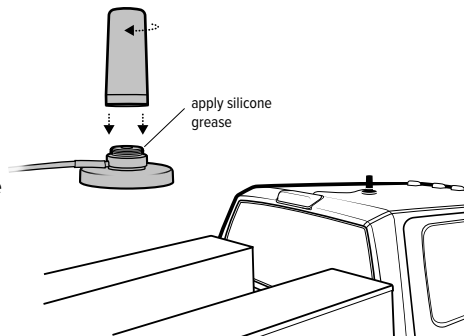

(STEP 1 cont.)

After running the cable through the third brake light into the vehicle, pull down the headliner so the cable can be routed into the vehicle cabin. Route the cable down the vehicle pillar to the desired booster location. After the cable is routed reattach the third brake light and put the headliner back into place.

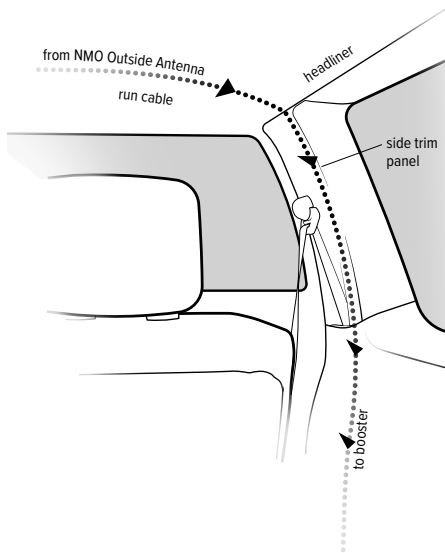

STEP 2 Mounting the Inside Antenna

Identify a place to mount the in-vehicle antenna, either on the side of the seat or on the dash and mount. The location should be at least 18 inches but no more than 36 inches from where the cellular device will be used. Use the Velcro® adhesive strip provided and attach to desired location.

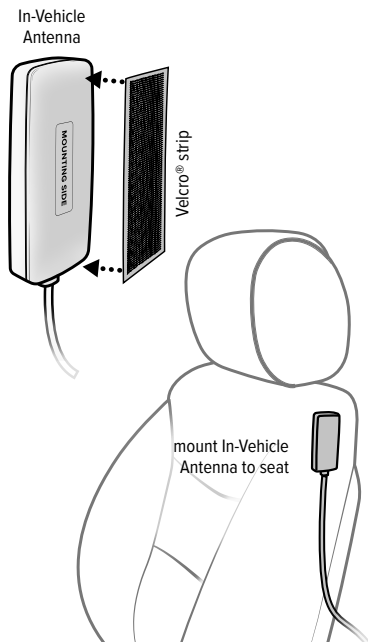

STEP 3 Hardwiring to Power

The Drive Reach Flex Fleet kit includes a CLA and Hardwire power option. The CLA power can be connected to a vehicle cigarette lighter port. Hardwire instructions are below. **Use the steps below as a general template for wiring the power. There are multiple options for wiring and steps will vary depending on the vehicle type.**

- Locate the vehicle fuse box. The fuse box location will vary by vehicle, refer to the vehicle's owner's manual.
- Route the power cable from the booster to the fuse box. If the fuse box is located under hood of the vehicle the cable will need to be ran through the firewall. Most vehicles will have a designated spot to run cable from the cabin to the engine bay.
- Determine which fuse to hardwire the power to. Find an open fuse slot that is ignition-switched. If there are no open fuse slots tied to the vehicle ignition, power can be attached to an existing fuse. Wiring to an ignition-switched fuse will ensure the booster is not drawing power when the vehicle is off. Refer to the vehicle owner's manual for information about the fuses.

Note: You can use a circuit tester to test if the fuse is constant or ignition-switched. A constant fuse will stay on when the vehicle is off, and an ignition-switched fuse will have power when the vehicle is on but no power when it is off.

(STEP 3 cont.)

- Connecting the power supply. Once you have determined a fuse slot to use connect the positive lead on the power cable to the included in-line fuse then attach to a fuse tap and crimp into place (fuse tap is not included in the kit and will vary by vehicle type). Connect the fuse tap to the fuse slot you have chosen.

Note: You will need to determine which type of fuse tap is needed to complete the power wiring. Variations include ATO, Mini, Low Profile and Micro2. Consult the vehicle owner's manual to determine which fuse is needed for your installation.

- Grounding the power supply. Most vehicle will have a factory grounding point. Slip the negative lead "black" on the power supply under the metal bolt on the grounding point and tighten into place.
- Testing the booster power. With the power supply hardwiring completed and inside and outside antennas in place, attach the power supply to the booster. Turn the vehicle ignition on and make sure the booster power light turns on. Then turn the ignition off to make sure the booster powers off.

STEP 4 Connect Coax Cables to Booster

Connect the cable from the outside antenna to the port labeled “Outside Antenna” on the booster and connect the cable from the inside antenna to the port labeled “Inside Antenna” on the booster.

Note: If the hardwire power option was implemented, booster will receive power only when ignition is on.

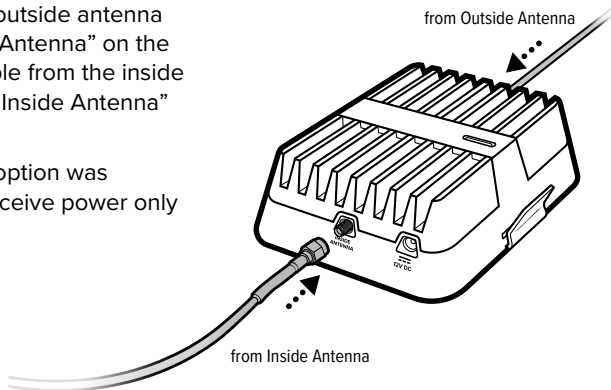

STEP 5 Connect Power Supply to Booster

Connect the 12V power supply cord to the end of the booster, labeled **"12V DC"** then plug the power adapter into vehicle's 12V DC power supply. Push switch to ON position. If your Drive Reach is working correctly, the light on the booster will be green. Use only the power supply provided in this package.

NOTE: If the 12V Cigarette Lighter port on your car is always on (even when your vehicle is turned off) and you will be parking for extended periods of time (more than a day), we recommend you turn the booster off by pushing power cord switch to OFF position. This will prevent the Drive Reach from draining the battery in your vehicle.

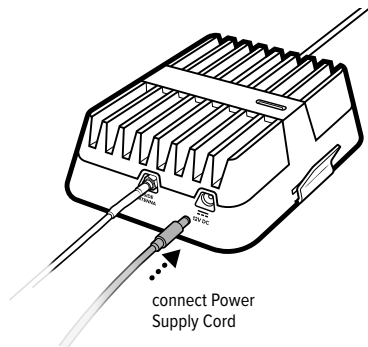

Booster Light Patterns

SOLID GREEN

This indicates that your Drive Reach booster is functioning properly and there are no issues with installation.

SOLID RED

Band has shutoff. This is due to a feedback loop condition called oscillation. This is a built in safety feature that causes a band to shut off to prevent harmful interference with a nearby cell tower. Refer to Troubleshooting section.

BLINKING RED, THEN SOLID GREEN

This indicates that one or more of the booster bands has reduced power due to a minor feedback loop condition called oscillation. This is a built in safety feature to prevent harmful interference with a nearby cell tower. If you are already experiencing the desired signal boost, then no further adjustments are necessary. If you are not experiencing the desired boost in coverage then refer to the Troubleshooting section.

Light Off

If the Drive Reach signal booster's light is off, verify your power supply has power.

(Booster Light Patterns cont.)

NOTE: The signal booster can be reset by disconnecting and reconnecting the power supply.

After troubleshooting you must initiate a new power cycle by disconnecting and then reconnecting power to the booster.

Troubleshooting

FIXING BLINKING OR RED LIGHT ISSUES

This section is only applicable if the booster is red or blinking red and you are not experiencing the desired signal boost.

- Unplug the booster's power supply.
- Relocate the inside and outside antenna further from each other. The objective is to increase the separation distance between them, so that they will not create this feedback condition discussed before.
- Plug power supply back in and ensure switch is in ON position.
- Monitor the indicator light on your booster. If, after a few seconds of 'power on', a solid or blinking red light appears, repeat prior steps. Increase the separation distance until the condition is corrected and/or desired coverage area is achieved.
Note: Horizontal separation of the two antennas typically requires a shorter separation distance than vertical separation.

If you are having any difficulties while testing or installing your booster, contact our weBoost Customer Support team for assistance (1-866-294-1660).

(Troubleshooting cont.)

FREQUENTLY ASKED QUESTIONS

How can I contact customer support?

Customer Support can be reached Monday through Friday by calling 1-866-294-1660, or through our support site at support.weboost.com.

Why do I need to create distance between the outside antenna and inside antenna?

Antennas connected to a booster create spheres of signal. When these spheres overlap, a condition called oscillation occurs. Oscillation can be thought of as noise, which causes the booster to scale down its power or shut down to prevent damage. The best way to keep these spheres of signal from overlapping is to maximize separation between the inside and outside antennas.

 1-866-294-1660

 www.weboost.com

 support@weboost.com

Safety Guidelines

Use only the power supply provided in this package. Use of a non-weBoost product may damage your equipment.

Connecting this signal booster directly to the cell phone with use of an adapter will damage the cell phone.

RF Safety Warning: Any antenna used with this device must be located at least 8 inches from all persons.

AWS Warning: The Outside Antenna must be installed no higher than 10 meters (31'9") above ground.

This is a **CONSUMER** device.

BEFORE USE, you **MUST REGISTER THIS DEVICE** with your wireless provider and have your provider's consent. Most wireless providers consent to the use of signal boosters. Some providers may not consent to the use of this device on their network. If you are unsure, contact your provider.

In Canada, **BEFORE USE** you must meet all requirements set out in ISED CPC-2-1-05.

You **MUST** operate this device with approved antennas and cables as specified by the manufacturer. Antennas **MUST** be installed at least 20 cm (8 inches) from (i.e., **MUST NOT** be installed within 20 cm of) any person.

You **MUST** cease operating this device immediately if requested by the FCC (or ISED in Canada) or licensed wireless service provider.

WARNING. E911 location information may not be provided or may be inaccurate for calls served by using this device.

(Safety Guidelines cont.)

FOR MORE INFORMATION ON REQUIREMENTS SET OUT IN ISED CPC-2-1-05, SEE BELOW:

<http://www.ic.gc.ca/eic/site/smt-gst.nsf/eng/sf08942.html>

FOR MORE INFORMATION ON REGISTERING YOUR SIGNAL BOOSTER WITH YOUR WIRELESS PROVIDER, PLEASE SEE BELOW:

T-Mobile/Sprint/MetroPCS: <https://www.t-mobile.com/support/coverage/register-a-signal-booster>

Verizon Wireless: <http://www.verizonwireless.com/wcms/consumer/register-signal-booster.html>

AT&T: <https://securec45.securewebsession.com/attsignalbooster.com/>

U.S. Cellular: <http://www.uscellular.com/uscellular/support/fcc-booster-registration.jsp>

Antenna Info

The following accessories are certified by the FCC to be used with the Drive Reach Booster.

This radio transmitter 4726A-460061 has been approved by innovation, Science and Economic Development Canada to operate with the antenna types listed below, with the maximum gain indicated. Antenna types not included in this list that have a gain greater than the maximum gain indicated for any type listed are strictly prohibited for use with this device.

	BAND 12/17	BAND 13	BAND 5	BAND 4	BAND 25/2
Outside antenna maximum permissible antenna gain (dBi) 50Ω	1.2	1.2	1.1	0.8	0.4
Inside antenna maximum permissible antenna gain (dBi) 50Ω	2.1	2.6	3.20	2.1	2.7

MOBILE INSIDE ANTENNA KIT OPTIONS

Kit #	Coax Type	Ln(ft)	Antenna Type	Ω
314401	LMR-100	10	4G Slim Low Profile SMA	50
314419	LMR-100	10	4G Slim Low Profile SMB	50
311160	RG-58	13	Desktop	50

MOBILE OUTSIDE ANTENNA KIT OPTIONS

Kit #	Coax Type	Ln(ft)	Antenna Type	Ω
311215	LMR-100	10	Mini-Mag SMB	50
311229	RG-58	15	4G Trucker	50
311230	RG-6	25	4G RV OTR	75
314405	RG-58	14	4G NMO	50

Specifications

Drive Reach Cell Signal Booster					
Model	460061				
FCC	PWO460061				
IC	4726A-460061				
Connectors	SMA Female				
Antenna Impedance	50 Ohms				
Frequency	698-716 MHz, 728-756 MHz, 777-787 MHz, 824-894 MHz, 1850-1995 MHz, 1710-1755/2110-2155 MHz				
Power output for single cell phone (Uplink) dBm	700 MHz B12/17 25.4	700 MHz B13 25.6	800 MHz B5 25.6	1700 MHz B4 26.7	1900 MHz B2 26.9
Power output for single cell phone (Downlink) dBm	4.8	4.8	4.8	4.6	4.5
Noise Figure	5 dB (nominal)				
Isolation	> 90 dB				
Power Requirements	12V 1.8A				

Each Signal Booster is individually tested and factory set to ensure FCC compliance. The Signal Booster cannot be adjusted without factory reprogramming or disabling the hardware. The Signal Booster will amplify, but not alter incoming and outgoing signals in order to increase coverage of authorized frequency bands only. If the Signal Booster is not in use for five minutes, it will reduce gain until a signal is detected. If a detected signal is too high in a frequency band, or if the Signal Booster detects an oscillation, the Signal Booster will automatically turn the power off on that band. For a detected oscillation the Signal Booster will automatically resume normal operation after a minimum of 1 minute. After 5 (five) such automatic restarts, any problematic bands are permanently shut off until the Signal Booster has been manually restarted by momentarily removing power from the Signal Booster. Noise power, gain, and linearity are maintained by the Signal Booster's microprocessor.

The term "IC" before the radio certification number only signifies that Industry Canada technical specifications were met. This device complies with Part 15 of FCC rules. This device contains licence-exempt transmitter(s)/receiver(s) that comply with Innovation, Science and Economic Development Canada's licence-exempt RSS(s). Operation is subject to the following two conditions: (1) This device may not cause interference, and (2) This device must accept any interference, including interference that may cause undesired operation of the device. Changes or modifications not expressly approved by weBoost could void the authority to operate this equipment.

✔ 3 YEAR WARRANTY

weBoost Signal Boosters are warranted for three (3) years against defects in workmanship and/or materials. Warranty cases may be resolved by returning the product directly to the reseller with a dated proof of purchase.

Signal Boosters may also be returned directly to the manufacturer at the consumer's expense, with a dated proof of purchase and a Returned Material Authorization (RMA) number supplied by weBoost. weBoost shall, at its option, either repair or replace the product.

This warranty does not apply to any Signal Boosters determined by weBoost to have been subjected to misuse, abuse, neglect, or mishandling that alters or damages physical or electronic properties.

Replacement products may include refurbished weBoost products that have been recertified to conform with product specifications.

RMA numbers may be obtained by contacting Customer Support.

DISCLAIMER: The information provided by weBoost is believed to be complete and accurate. However, no responsibility is assumed by weBoost for any business or personal losses arising from its use, or for any infringements of patents or other rights of third parties that may result from its use.

Register your Signal Booster now!

Complete the two easy steps to register your booster and receive premium customer service, special offers and more!

Step 1: Take a photo of your Photoregister Code including the points (⦿).

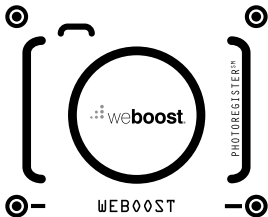

Step 2: Send it in.



Smartphone U.S. only
Text photo to 71403

OR



Email U.S./CAN
weboost@photoregister.com

OR



Online
register.weboost.com

Need help? Visit photoregister.com/help or text HELP to 71403.

Notes



 1-866-294-1660

 www.weboost.com

 support@weboost.com



3301 East Deseret Drive, St. George, UT

 1.866.294.1660  www.weboost.com  support@weboost.com

Copyright © 2021 weBoost. All rights reserved. Wilson Electronics products covered by U.S. patent(s) and pending application(s)
For patents go to: weboost.com/us/patents

NOT AFFILIATED WITH WILSON ANTENNA

GDE000467_003_03.25.22